

PART

NUMBER: LMX4622BJL4

Product Features

- Each output provides up to 2.5A current
 - Wide input voltage range: 3.6V to 20V
 - Output voltage: 0.6V to 5.5V (adjustable)
 - Output current: Each channel provides up to 2.5A DC
 - Operating frequency: 1MHz
 - Current-mode control with fast transient response
 - Parallel current sharing; single module can be paralleled for 5A output
 - Soft-start and output voltage tracking
 - External frequency synchronization
 - Overcurrent and overheat protection
 - Total ionizing dose (TID): $\geq 50\text{kRad (Si)}$
 - Single event effect immunity: SEL, SEU, and SEB $\geq 75\text{MeV}\cdot\text{cm}^2/\text{mg}$
-

Functional Description

The radiation-hardened LMX4622BJL4 is a dual-channel step-down micro-module regulator with radiation-hardening specifications. It uses plastic packaging to meet full-temperature-range operation requirements. The control IC is fabricated using $0.18\ \mu\text{m}$ BCD technology and housed in a BGA25 package with typical dimensions of $6.25\text{mm} \times 6.25\text{mm} \times 2.42\text{mm}$. It operates within a typical ambient temperature range of -55°C to $+125^\circ\text{C}$. The input voltage range is 3.6V to 20V, and the output voltage range is 0.6V to 5.5V. It provides dual-channel 2.5A current, and when the two channels are used in parallel, it can deliver up to 5A current on a single output.

The LMX46XX series products cover a wide range of variants, including standard versions, radiation-hardened versions, plastic-encapsulated and ceramic-encapsulated packages. They are available in multiple quality grades: industrial grade, extended temperature grade, M1 grade, and N1 grade, with 24 models in total.

All products are independently developed and designed using original forward architecture with wafer fabrication and packaging completed in China. They have obtained national certification for independent and controllable core technologies, successfully breaking the “bottleneck” in high-end power chip development.

These products serve as pin-to-pin replacements for the Linear Technology (ADI) LTM46XX series, while outperforming them in key parameters. The company attaches great importance to product quality and has established a comprehensive quality system, certified with ISO9001 and GJB9001C.

Supported by the rapid development of China's semiconductor industry, Langma Innovation deeply serves domestic special industries and has delivered high-performance, high-precision, high-reliability, and cost-effective domestic chips in large volumes.

In the future, the company will continue to build a national leading brand, providing more comprehensive solutions for communications, radar, computing, artificial intelligence, automation, naval vessels, aviation, aerospace, and other equipment fields, and promoting industrial innovation and development.

典型应用原理图

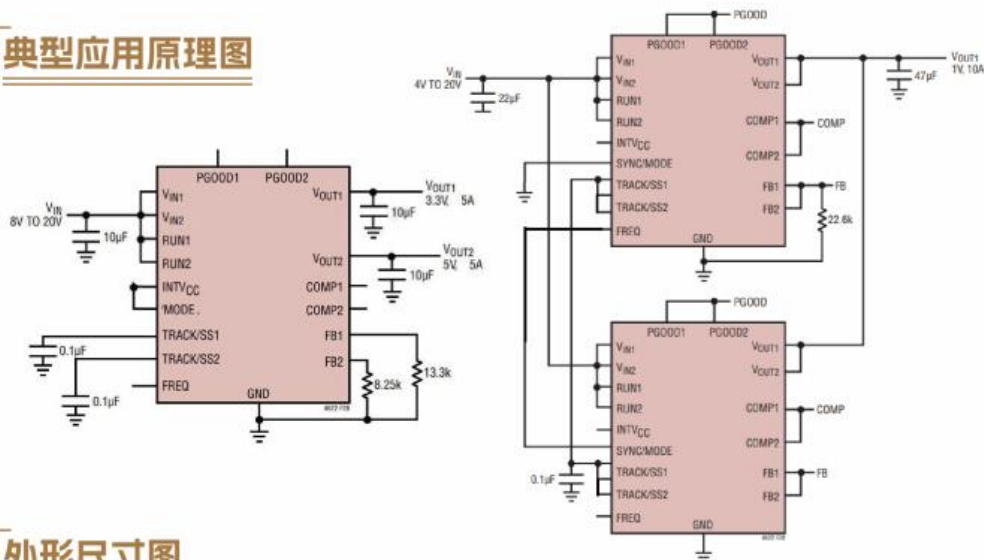

外形尺寸图

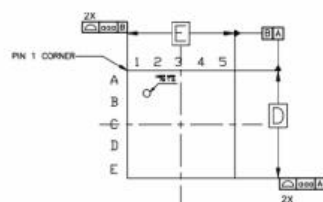

TOP VIEW

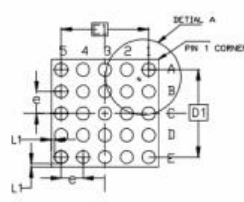

BOTTOM VIEW

SYMBOL	MILLIMETER		
	MIN	NOM	MAX
A	2.36	2.42	2.48
A3	1.50 BASIC		
A2	1.77	1.82	1.87
A1	0.55	0.60	0.65
c	0.28	0.32	0.36
E	6.15	6.25	6.35
E1	5.08 BASIC		
D	6.15	6.25	6.35
D1	5.08 BASIC		
b	0.71	0.76	0.81
L1	0.205 REF		
e	1.270 BASIC		
aaa	0.15		
ccc	0.10		
ddd	0.20		
eee	0.30		
fff	0.15		

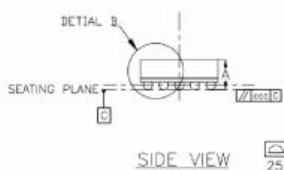

SIDE VIEW

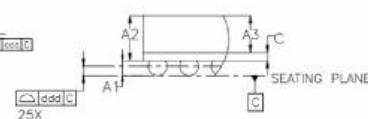

DETAIL B (2:1)

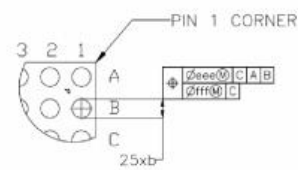

DETAIL A (2:1)

内部原理框图

